



VACUUM
PLUMBING
SYSTEMS



CONDENSATE
WASTE WATER
COLLECTION

FOR

SUPERMARKETS • CONVENIENCE STORES • DELICATESSENS



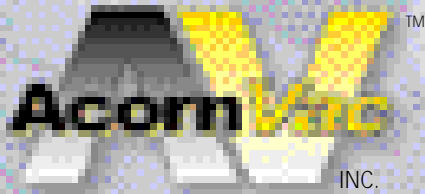

ACORNVAC MANUFACTURING COMPLEX,
CHINO, CALIFORNIA

As an subsidiary of Acorn Engineering Company, AcornVac Inc. continues its 50 year tradition of setting industry standards with innovative products and systems. Using modern technology, AcornVac Inc. offers an alternative system to transport wastewater using vacuum. With a 10 year association of vacuum designed projects, AcornVac Inc. ensures that our customers continue to receive the best products and latest technology available. Acorn Engineering Company manufactures a wide variety of products including:

- Stainless Steel Plumbing Fixtures and Accessories
- Hospital Equipment and Accessories
- Injection Molded Products
- Water Heating Equipment



ACORN ENGINEERING CORPORATE HEADQUARTERS
AND MANUFACTURING COMPLEX,
INDUSTRY, CALIFORNIA

VACUUM: A FLEXIBLE &

To maintain a competitive edge, supermarkets must continually strive to maintain and expand its customer base. AcornVac vacuum plumbing systems allow unlimited flexibility in the arrangement and presentation of merchandise (products) at a significant cost savings compared to traditional remodeling strategies. Cost reductions are realized in both reduced material and construction costs as well as reduced downtime for the affected floor space.

What is an AcornVac Wastewater Collection System?

It is an engineered plumbing system that uses vacuum and air to transport condensate or wastewater through a network of overhead piping to a central collection location, which is then discharged into the sewer main. The AcornVac Condensate Collection System gives owners an alternative to conventional under-slab piping systems. It reduces the cost of remodeling, installs quickly and provides store layout flexibility.

Compare:

Vacuum	Gravity
1. Flexibility in case layout and arrangement for new construction or remodeling.	1. Case layout is limited to where floor sinks (drains) are located. Flexibility is limited.
2. Eliminates the cost of under-slab wastewater piping. Piping system is installed overhead. Does not require venting.	2. Drain lines are installed beneath concrete slab. Requires venting.
3. Installation costs are reduced using smaller diameter plastic pipe and fittings. Floor Drains are eliminated.	3. Uses standard drainage pipe and fittings. Requires floor drains and cleanouts.
4. Remodeling time is reduced. No concrete cutting and trenching.	4. Remodeling requires costly concrete cutting, trenching and drain relocation.
5. Leaking pipes. Air will enter waste piping. No wastewater leaks.	5. Leaking pipes. Wastewater will exit waste piping causing potential ground damage.

ECONOMIC ALTERNATIVE TO GRAVITY

- Saves time and 💰 money in new construction and remodeling costs
- Eliminates under-slab drain piping
- Provides unlimited flexibility in case arrangement

Below is a typical supermarket design showing the flexibility of using an overhead vacuum piping system. This design can include flows from case washdown, multiple defrost cycles and from other gray-water producing areas. Using the AcornVac vacuum plumbing system, substantial 💰 savings can be realized in material and labor costs.

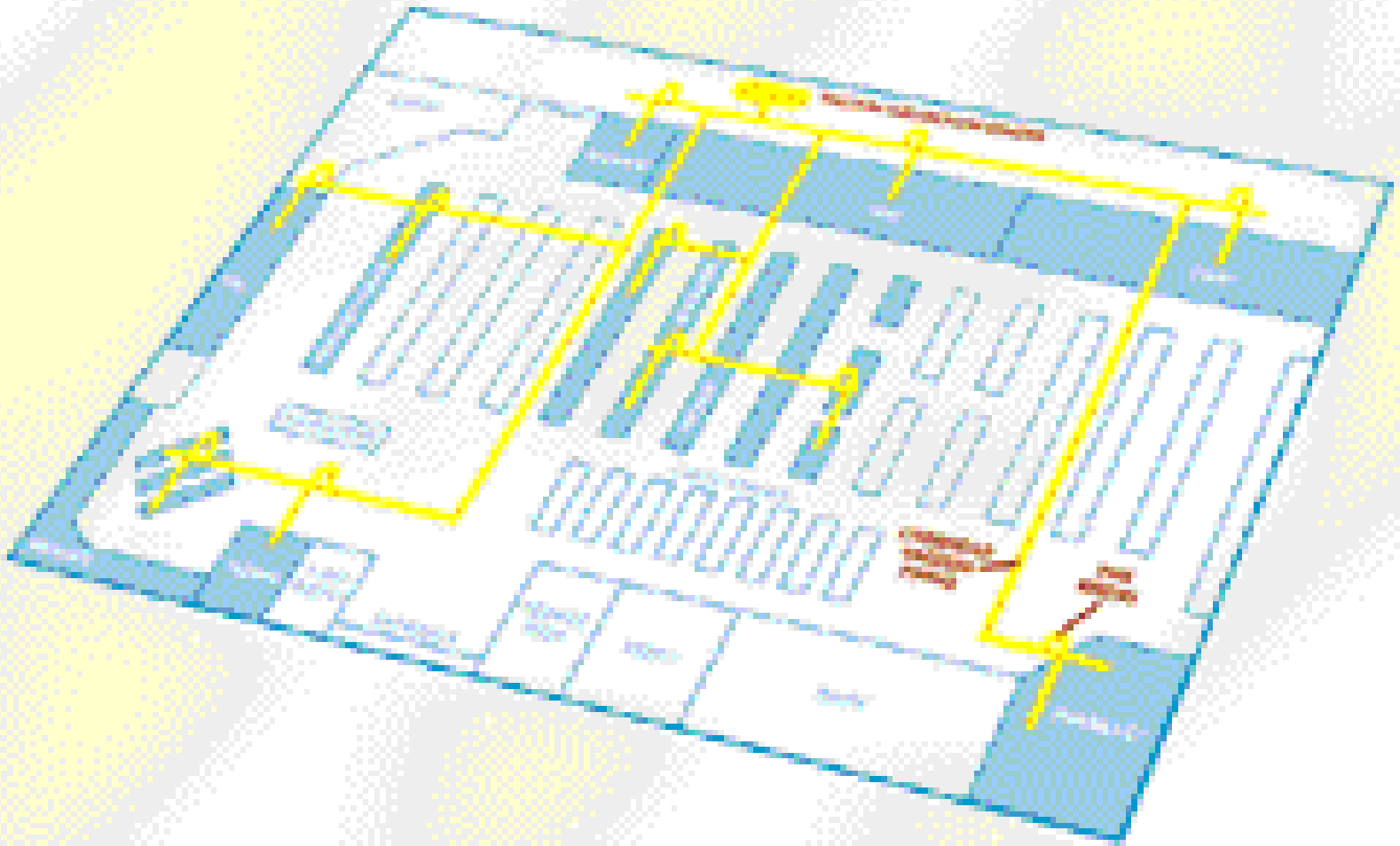

Vacuum can be used with any supermarket case.

Dairy Cases



Meat Cases



Frozen Food Cases



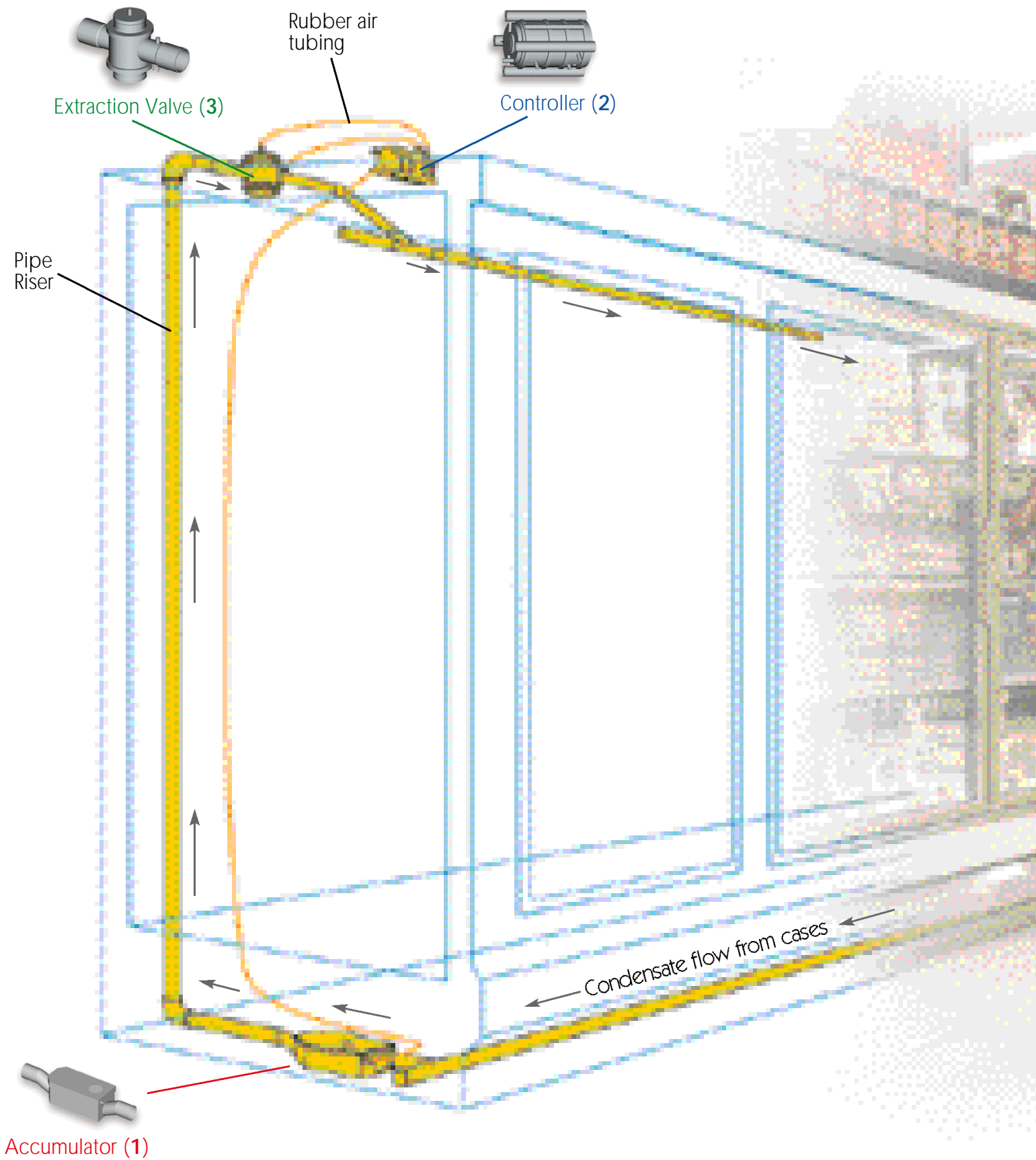

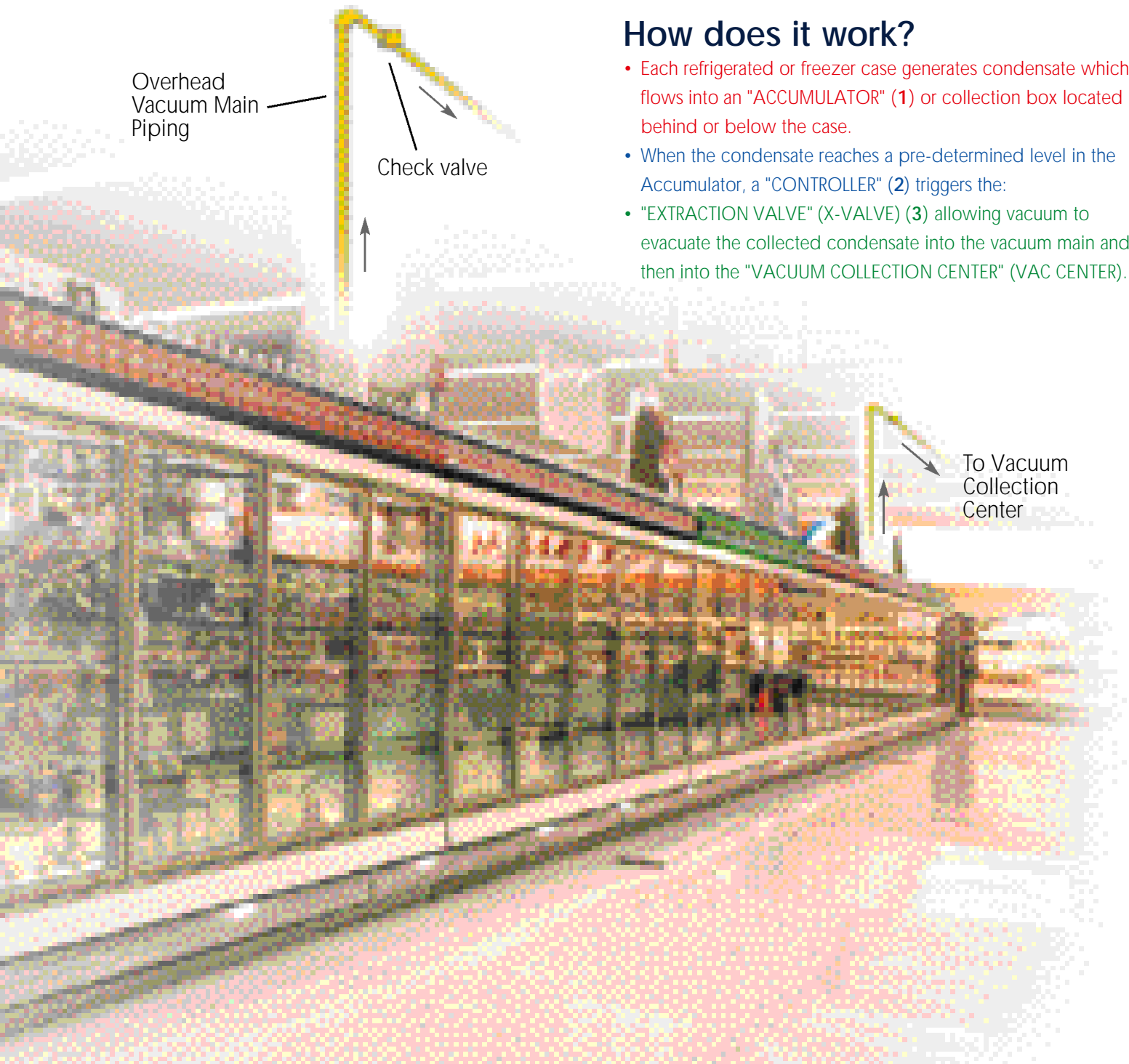

How does it work?

- Each refrigerated or freezer case generates condensate which flows into an "ACCUMULATOR" (1) or collection box located behind or below the case.
- When the condensate reaches a pre-determined level in the Accumulator, a "CONTROLLER" (2) triggers the:
- "EXTRACTION VALVE" (X-VALVE) (3) allowing vacuum to evacuate the collected condensate into the vacuum main and then into the "VACUUM COLLECTION CENTER" (VAC CENTER).

Deli Cases



Produce Cases



Vacuum Collection Center

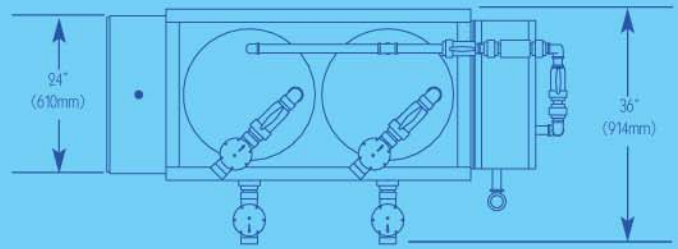

Top View

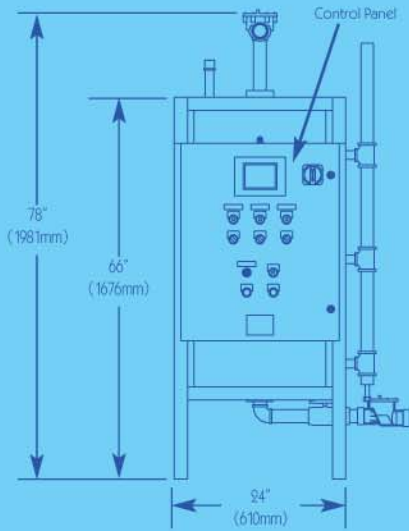

Left Side View

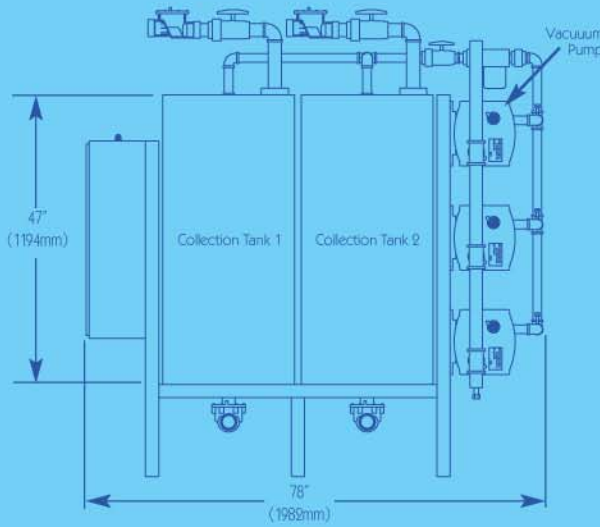

Front View

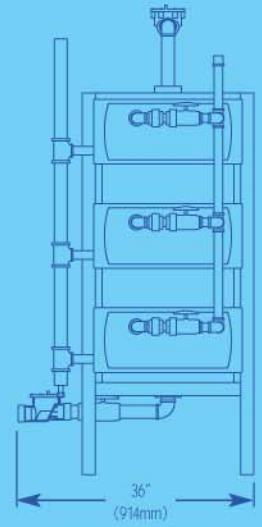

Right Side View

Control Panel

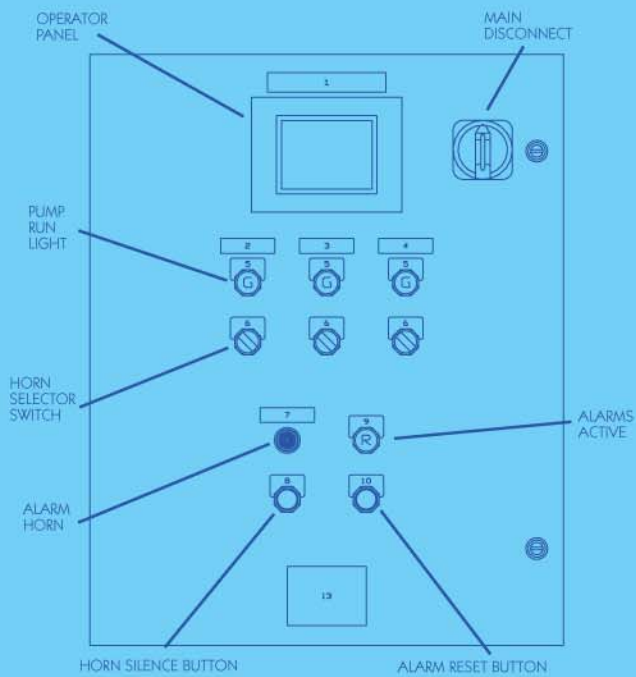

NEMA 4 Enclosure
30"H X 24"W X 8"D

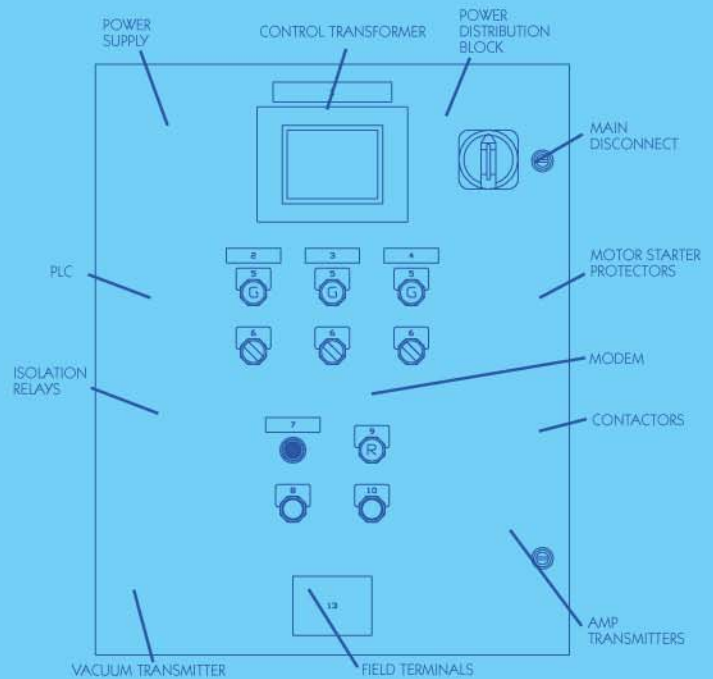

Inner Panel Layout

AcornVac™ Condensate Collection System

Sample Specification

General Information

The AcornVac Condensate Collection System shall include the following:

1. Vacuum Collection Center (Vac Center)
2. Vacuum Piping network and components

Licensed contractors shall install the system in accordance with local plumbing and electrical codes.

Refer to contract documents for individual components supplied by the manufacturer and those supplied by the installing contractors.

Vacuum Collection Center (Vac Center)

The Vacuum Collection Center (Vac Center) shall consist of a pre-packaged unit, which includes collection tanks, vacuum pumps, sensors, valves, piping and an electrical control panel.

Sizing of the Vacuum Collection Center (Vac Center) will be subject to manufacturer's recommendation.

The Vacuum Collection Center (Vac Center) will be Model: _____

Electrical requirements are as follows:
_____ Vac, _____ Phase _____ Hz

The electrical control panel shall meet all National and Local electrical codes and must include a UL508 Label.

The electrical control panel must include a vacuum transmitter to measure the actual system pressure for use in valve and pump sequencing.

The control panel shall be programmed to allow equal operation of all vacuum pumps.

Vacuum Piping Network

The piping network shall be separate from the sanitary drainage system. The piping network shall be installed and connected to refrigerated display cases and other fixtures as indicated on the contract documents.

The vacuum piping network shall utilize plastic or copper pipe and fittings where specified.

The manufacturer will provide installation layout and instructions.

The vacuum piping network shall include the following components:

1. Vertical Pipe Risers - multiple vertical risers connected to the overhead vacuum main which transport the condensate or wastewater to the Vacuum Collection Center (Vac Center). Quantity as identified on contract documents.
2. Accumulator - placed below or behind the refrigerated case and attaches to a vertical pipe riser that connects to a vacuum main. Quantity as identified on contract documents.
3. Extraction Valve Kit - includes a controller, Extraction Valve, rubber tubing, mounting bracket. When the condensate or wastewater reaches a pre-determined level in the Accumulator, the controller shall open the Extraction Valve, allowing vacuum to transport the condensate or wastewater to the Vacuum Collection Center.

Factory Authorized Start-up and Inspection

The manufacturer will inspect the installation of the vacuum piping network and connection to the Vacuum Collection Center (Vac Center) and will provide an initial start-up upon completion.





ACORN'S DIVISIONS, SUBSIDIARIES AND JOINT VENTURES

Acorn Engineering Company, Inc.

15125 Proctor Avenue • City of Industry, CA 91746 U.S.A.
(800) 488-8999 • (626) 336-4561 • Fax (626) 961-2200
International Fax 1-626-937-4757
www.acorneng.com



Elmdor/Stoneman Access Doors and Roof Flashing Assemblies

500 South Azusa Avenue • P.O. Box 3527
City of Industry, CA 91744 U.S.A.
(800) 591-9181 • (626) 968-8699 • Fax (626) 333-4109
www.elmdorstoneman.com



Super Secur Manufacturing Company Park and Recreation Buildings

15125 Proctor Avenue • City of Industry, CA 91746 U.S.A.
(800) 591-9880 • (626) 333-2543 • Fax (626) 855-4860
www.supersecur.com



Whitehall Manufacturing Healthcare Products Division

15125 Proctor Avenue • City of Industry, CA 91746 U.S.A.
(800) 782-7706 • (626) 968-6681 • Fax (626) 855-4862
www.whitehallmfg.com



Acudor/Acorn Ltd.

1734 Orangebrook Court
Pickering, Ontario, Canada L1W 3G8
(905) 839-7165 • Fax (905) 839-8230
www.acudoracornltd.com



Acorn-Gencon Plastics Injection Molded Products

13818 Oaks Avenue • Chino, CA 91710 U.S.A.
(909) 591-8461 • Fax (909) 628-7465
www.acorn-gencon.com



Cal Tube Industries Tubular Plumbing Products/Strainers

13818 Oaks Avenue • Chino, CA 91710 U.S.A.
(800) 225-8823 • (909) 591-8461 • Fax (909) 628-7465
www.caltube.com



Chronomite Laboratories, Inc.

1420 W. 20th Street • Harbor City, CA 90710
(800) 447-4962 • (310) 534-2300 • Fax (310) 530-1381
www.chronomite.com



Acorn Powell, Ltd.

Unit 4, Barratt Industrial Park
St. Oswald's Road
Gloucester GL1 2SH • United Kingdom
Tel: 00 44 1452 33 22 24 • Fax: 00 44 1452 33 22 25
www.acornpowell.co.uk

CONTACT US BY PHONE



800-591-9920 Toll Free

CONTACT US BY FAX



909-902-5041

WEB SITE



L1000583

www.acornvac.com
email: info@acornvac.com



VACUUM PLUMBING SYSTEMS
Subsidiary of Acorn Engineering Company

13818 Oaks Avenue • Chino, CA 91710 U.S.A.
(800) 591-9920 • (909) 902-1141 • Fax (909) 902-5041
www.acornvac.com